

# RTS Series Package 01, 02

With slotted angle bracket

Side load aluminum door and frame

## Installation instructions

08280321 – 02-2020

| EN |

dormakaba 

# Table of contents

<b>1</b>	<b>Installation instructions</b>	<b>3</b>
1.1	Prepare frame and install closer	3
1.2	Prepare top of door and install closer arm	4
1.3	Prepare bottom of door and install pivot	5
1.4	Install door	6
<b>2</b>	<b>Adjustments</b>	<b>7</b>
2.1	Door alignment	7
2.2	Clearance adjustments (if required)	8
<b>3</b>	<b>Door removal</b>	<b>9</b>
2.3	Adjust closing speeds	9

# 1 Installation instructions

## 1.1 Prepare frame and install closer

Fig.1

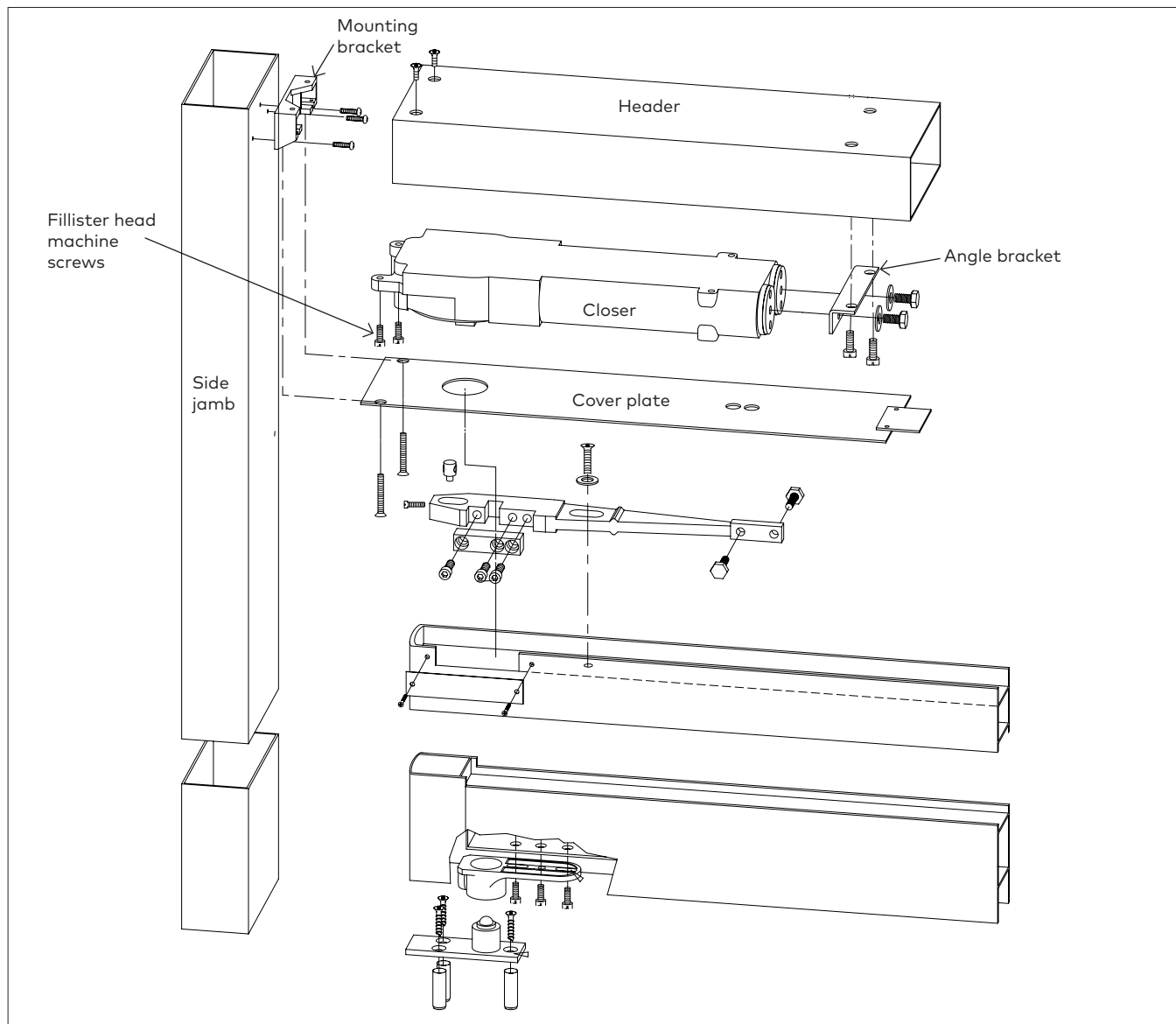

- 1.1.1 Prepare header and side jamb according to template.
- 1.1.2 Fasten mounting bracket to side jamb with three No. 8-32 pan head machine screws.
- 1.1.3 Fasten header to side jamb with two No. 10-32 flat head machine screws.
- 1.1.4 Fasten angle bracket to closer with two hex head machine screws and flat washers.
- 1.1.5 Install 2 fillister head machine screws into mounting tabs on closer; make approximately 3 turns.

**NOTE: For RTS88 models only - do not remove spacer washers in mounting tabs.**

- 1.1.6 Install closer into header by inserting mounting tabs into mounting bracket.
- 1.1.7 Raise end of closer with angle bracket into header.
- 1.1.8 Fasten angle bracket with the two 1/4-20 pan head machine screws.
- 1.1.9 Closer should remain centered in header.
- 1.1.10 Tighten the 2 fillister head machine screws securely.
- 1.1.11 Install cover plate by sliding tab into frame.
- 1.1.12 Fasten opposite end to mounting bracket with two No. 8-32 flat head machine screws provided.

## 1.2 Prepare top of door and install closer arm

Fig.2

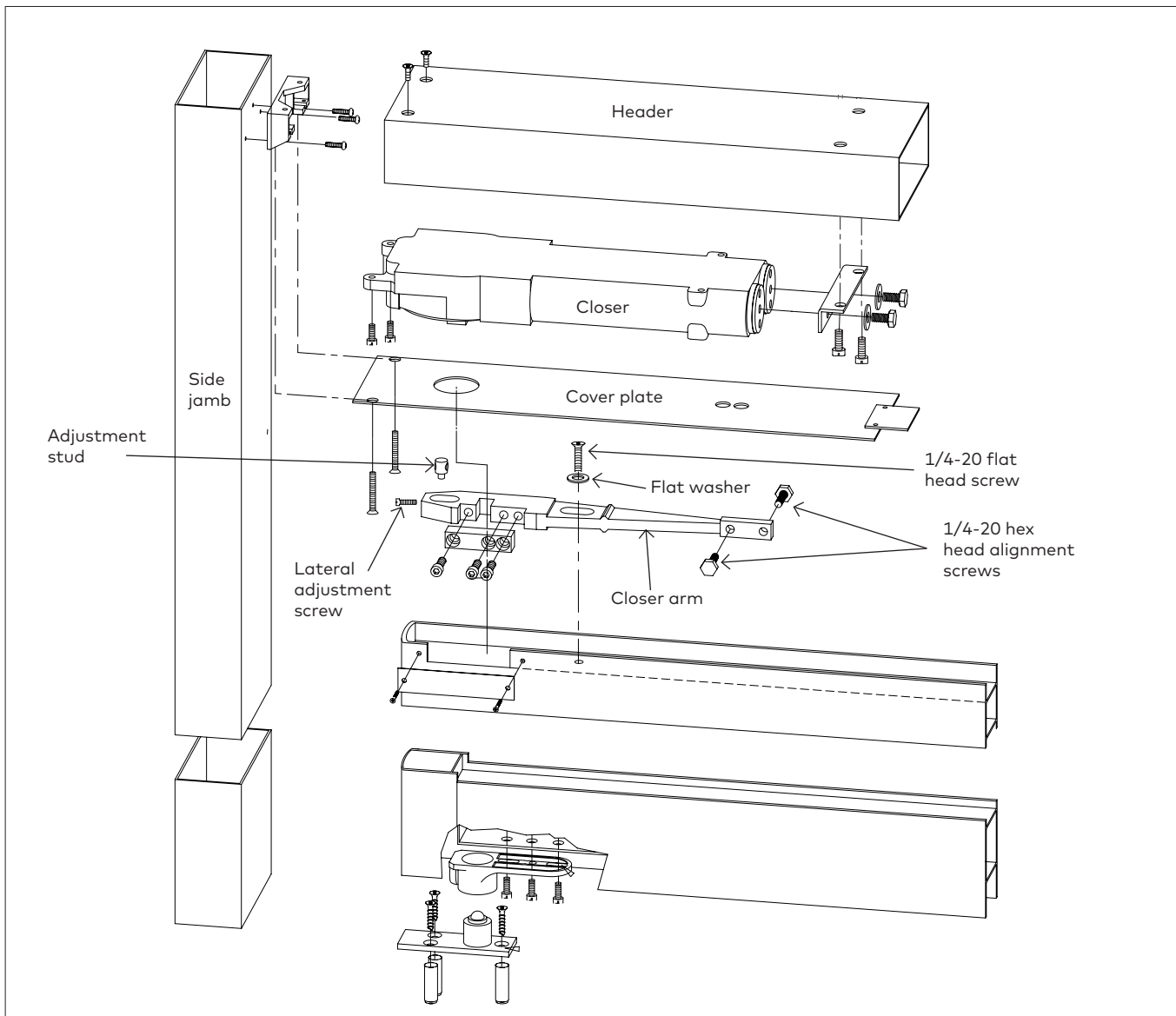

1.2.1 Prepare top of door according to template.

**NOTE:** Cut-out side of door should face interior of building.

1.2.2 Fasten adjustment stud to door channel.

1.2.3 Install two 1/4-20 hex head alignment screws into closer arm.

1.2.4 Place closer arm over adjustment stud in door channel.

1.2.5 Center arm in door, turning both 1/4-20 hex head alignment screws counter-clockwise until they are wedged against door channel.

1.2.6 Thread lateral adjustment screw into adjustment stud.

1.2.7 Secure arm into place with 1/4-20 flat head screw and flat washer.

### 1.3 Prepare bottom of door and install pivot

Fig.3

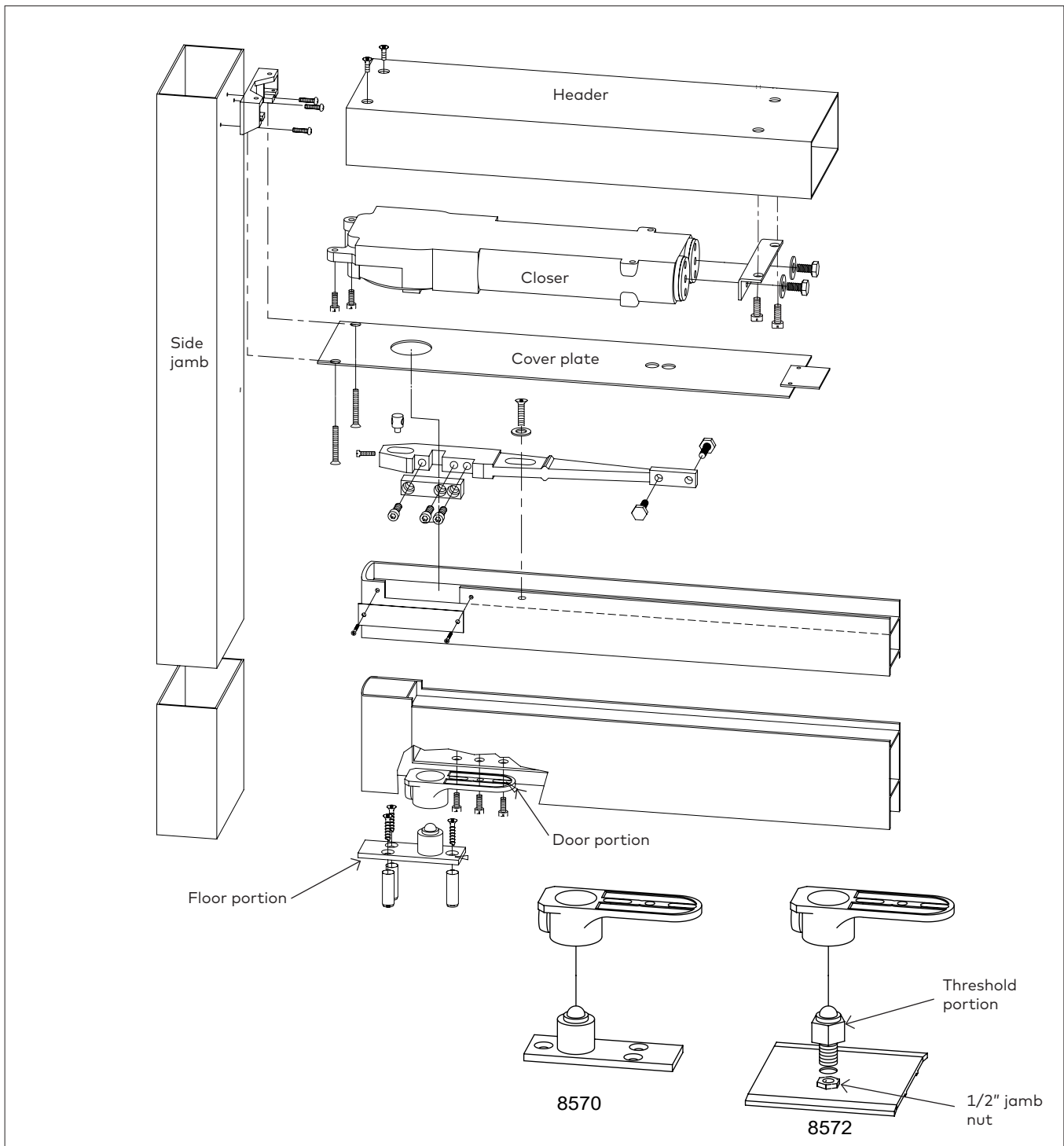

- 1.3.1 Prepare bottom of door according to template.
- 1.3.2 Fasten door portion of bottom pivot with three 1/4-20 pan head machine screws.
- 1.3.3 Prepare floor or threshold according to template.

- 1.3.4 Fasten floor portion with three No. 12 flat head wood screws and plastic anchors.
- 1.3.5 If threshold is used, fasten threshold portion of bottom pivot with 1/2" jamb nut.

## 1.4 Install door

Fig.4

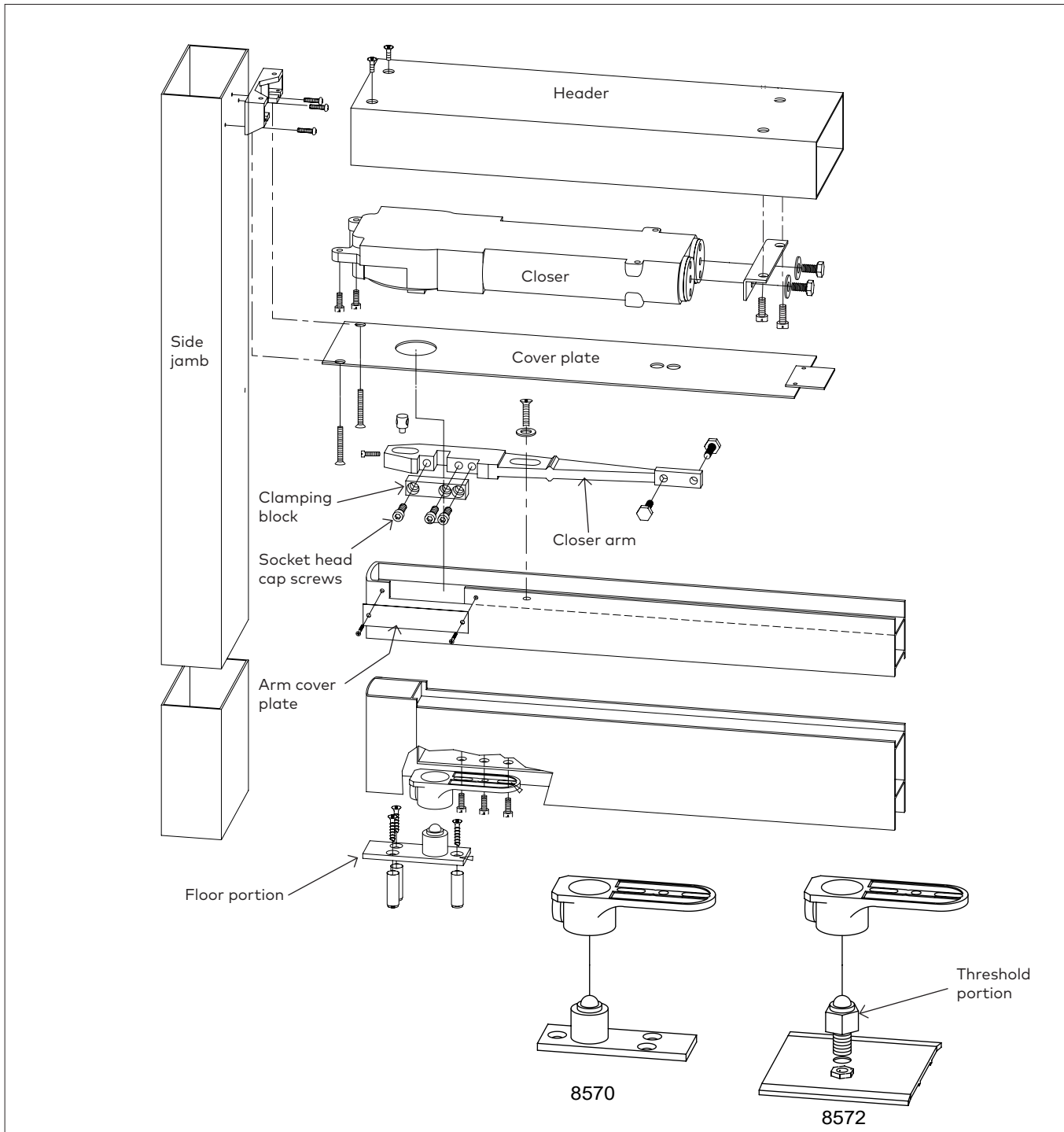

1.4.1 With door parallel to opening, place bottom of door onto floor or threshold portion of pivot.

1.4.2 Push door to vertical position until closer spindle is completely engaged into closer arm.

1.4.3 Fasten clamping block to arm with three 1/4-20 socket head cap screws.

**NOTE: Alternate fastening screws when tightening clamping block.**

1.4.4 Fasten arm cover plate to door with screws provided.

## 2 Adjustments

### 2.1 Door alignment

Fig.5

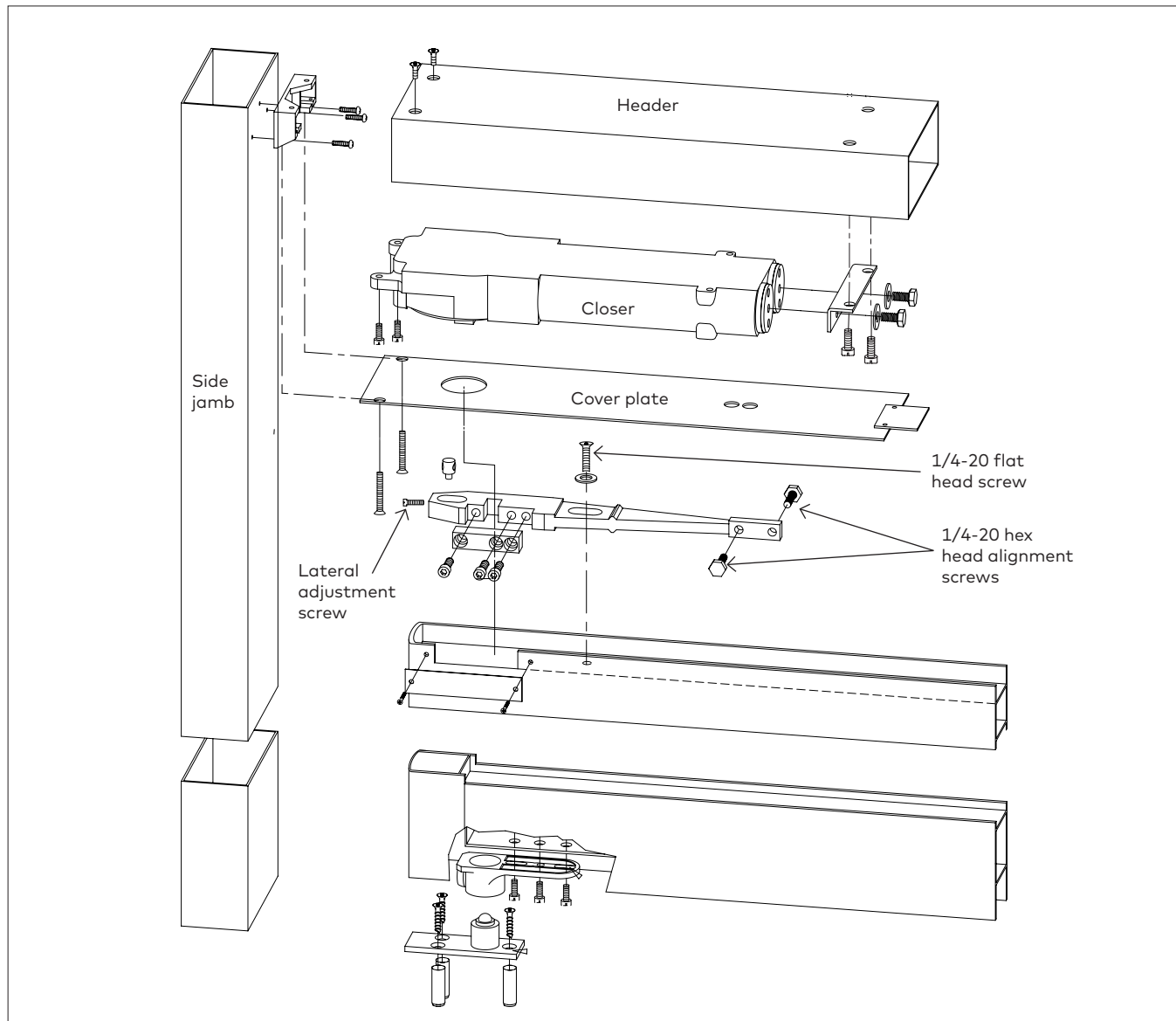

#### 2.1.1 Double acting -

- Center door in frame by loosening 1/4-20 flat head screw and adjusting the two 1/4-20 hex head alignment screws as required.
- To adjust clearance between door and frame, adjust lateral adjustment screw.
- Retighten 1/4-20 flat head screw.
- **TIGHTEN SECURELY!**

#### 2.1.2 Single acting -

- Adjust arm to insure that door closes tightly against stop.
- Loosen 1/4-20 flat head screw.
- Adjust closer arm fully in the direction of door swing.
- To adjust clearance between door and frame, adjust lateral adjustment screw.
- Retighten 1/4-20 flat head screw.
- **TIGHTEN SECURELY!**

## 2.2 Clearance adjustments (if required)

Fig.6

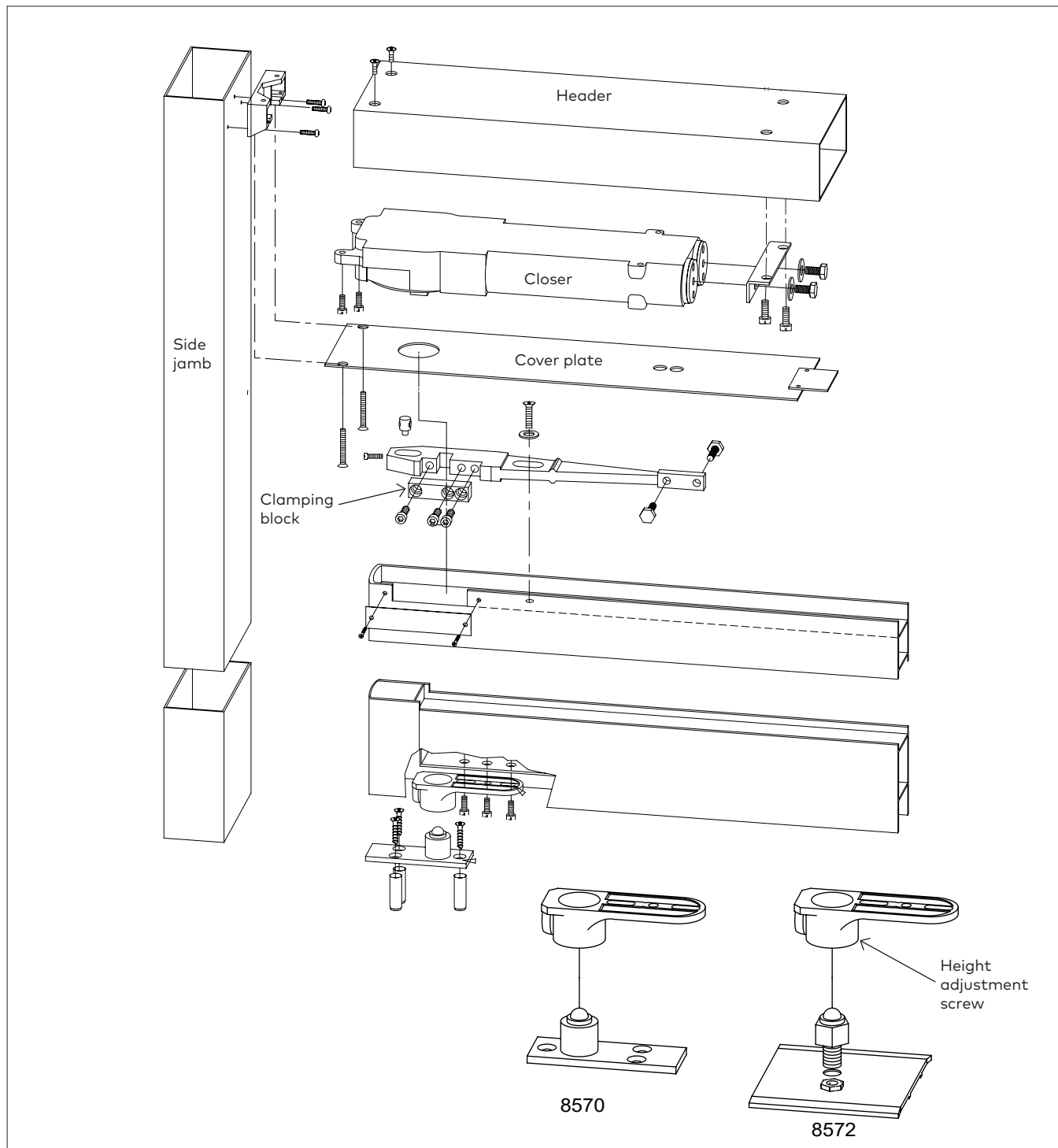

2.2.1 If clearances differ from those shown on the template, adjust in the following manner.

2.2.2 Adjust pivot art no. 8570, 8572 by opening door to approximately 90°.

2.2.3 Loosen clamping block on closer arm.

2.2.4 With small flat blade screwdriver, turn height adjustment screw through 3/8" diameter clearance hole in heel edge of door.

- Clockwise - raises the door  
 Counter-clockwise - lowers the door

2.2.5 Retighten clamping block.

2.2.6 TIGHTEN SECURELY!



## 2.3 Adjust closing speeds

Fig.7

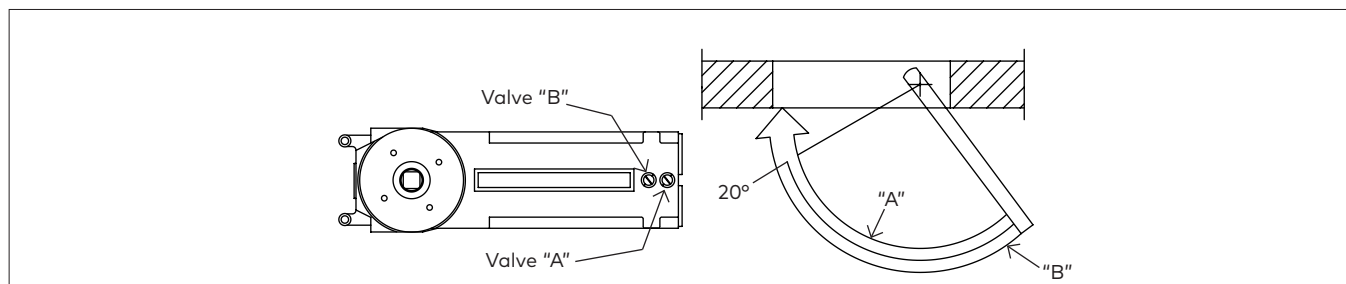

2.3.1 Valve "A" - controls closing speed from maximum opening angle to 0°.

- Clockwise - decreases closing speed
- Counter-clockwise - increases closing speed

2.3.2 Valve "B" - increases closing speed from maximum opening angle to 20°.

Counter-clockwise - increases closing speed.

## 3 Door removal

Fig.8

